

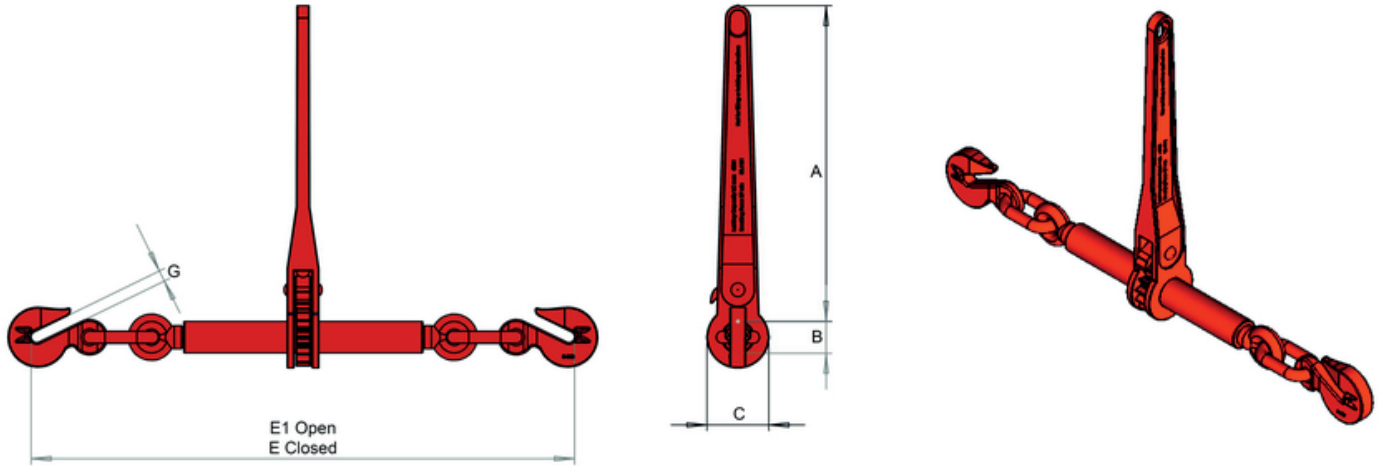

### Lashing Equipment - Commercial

#### Commercial Ratchet Loadbinder



Part Code	To suit Chain Size mm	MBL t	Weight kg	A mm	B mm	C mm	E mm	E1 mm	G mm	Box Qty
MB1.095.R	8-10	8.6	4.1							5
MB1.130.R	10-13	15	5.5	335	34	63	585	810	15	5
MB1.160.R	13-16	21	7.1	335	36	63	645	840	17	4

#### Drop Forged Over-Centre Loadbinder



Part Code	To suit Chain Size mm	M.B.L. t	Weight Kg	Box Quantity
MB1.095.F	8-10	8.6	3.8	5



### Grade 30 Short Link Chain

- Finish: Self Colour
- Test: Batch Tested and Certified

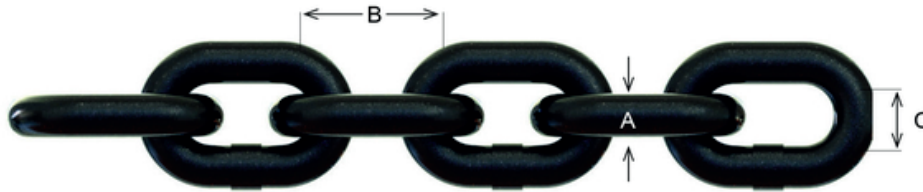

Part Code	Chain Size (mm)	A (mm)	B (mm)	C (mm)	M.B.L. (t)	Meter Per Drum	Weight Per M (Kg)
1.080.G40	8	8	24	12	4.0	350	1.40
1.100.G40	10	10	30	14	6.0	250	2.20
1.120.G30	12	12	36	16	7.0	150	3.20
1.160.G30	16	16	45	22	12.5	100	5.60